



AI-14 OBD-II Installation Guide

April 2026

Version 3.0

This guide covers OBD-II power connection installations only.
For hardwired fuse-box installations, refer to the AI-14 Hardwire Installation Guide.

Safety Instructions and Warnings

WARNING: THE DEVICE SHOULD BE INSTALLED AND MAINTAINED BY QUALIFIED TECHNICIANS. Only a properly qualified technician should install and maintain the Surfsight powered by Lytx dashcam device(s). Any electrical work should be performed only by a suitably trained and qualified automotive technician with qualification applicable to your country/region/state; and with expertise in installing and troubleshooting advanced onboard components, including multiplexed circuits. Lytx, Inc. disclaims all responsibility for any damages arising from improper installation and maintenance of the Surfsight device(s). This guide is protected as confidential and proprietary information of Lytx, Inc. Copying and using this guide for any purpose other than installing Surfsight Device(s) in vehicles of Lytx, Inc.'s customers is expressly prohibited. Information contained in this guide was in effect as of the date set forth above and is subject to change without notice or liability. Lytx, Inc. reserves the right to revise the information presented or to discontinue the production of parts described at any time.

WARNING: Some countries/regions/jurisdictions have adopted, or may in the future adopt, laws that prohibit objects from being mounted on a vehicle's windshield or other locations in a vehicle. Always refer to any applicable laws that concern mounting devices on vehicle windshields before choosing a mounting location. You are responsible for complying with such laws, as Lytx, Inc. does not accept responsibility for your failure to do so.

WARNING: Use of correct Personal Protective Equipment to comply with any countries/regions/jurisdictions/local company Health and Safety regulation for the installation site and type of installation being completed, to prevent serious injury, is the responsibility of the Installer and Installation partner. Wear safe eye protection to prevent serious injury when you perform vehicle maintenance or service.

WARNING: Do not disconnect equipment unless power has been removed and the area is known to be non-hazardous. Comply with all Electrically propelled/non-Internal Combustion Engine vehicle(s). Health and Safety regulation within countries/regions/jurisdictions. Any electrical work on Electrically propelled vehicle(s) should be performed only by a suitably trained and qualified automotive technician to international level 1 EV qualification applicable to your country/region/state. Lytx, Inc. disclaims all responsibility for any damages arising from improper installation and maintenance of the Surfsight device(s).

Table of Contents

1. Getting Started	4
1.1 Unbox the AI-14 Dashcam	4
1.2 Additional Items Required	5
1.3 Identify Your Mounting Bracket	6
2. Pre-Installation Checklist	7
3. OBD-II Port Setup	8
3.1 Connect to the Vehicle's OBD-II Port	9
3.2 Configure Virtual Ignition	11
3.3 Adjust Dashcam Settings	11
4. Position the Dashcam	12
4.1 Regulatory Guidance	12
4.2 Set the Viewing Angles	13
4.3 Choose a Mounting Location	14
5. Mount the Dashcam	16
5.1 Position and Install the Mounting Bracket	16
5.2 Secure the Dashcam to the V1 or V2 Mounting Bracket	17
6. ADAS Calibration	20
6.1 Measurement Guidance	21
6.2 Enter Measurements in Dashcam ADAS Settings	23
7. Post-Installation Checklist	25
7.1 Final Checks and Functionality	25
8. OBD-II Mounting Adapters	26
9. Frequently Asked Questions	27
10. Service and Audit Calls	29
11. De-Installation	30
12. Safety Warnings Reference	31

1. Getting Started

1.1 Unbox the AI-14 Dashcam

Confirm that the box contains all of the following items:

- AI-14 dashcam with pre-installed SIM and Micro-SD cards
- Mounting bracket (V1 or V2 – see [Section 1.3](#) to identify yours)
- QR code card linking to installation instructions
- T6 Torx wrench
- Alcohol wipes
- Notification window sticker



WARNING: DO NOT carry the AI-14 dashcam by the power cable or TWIST the right-angle strain relief molding of the connected power cable.

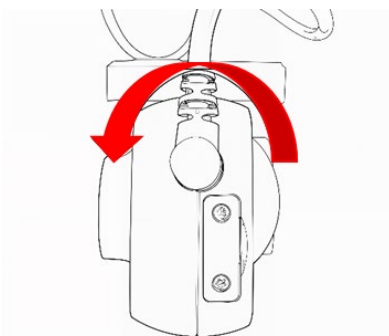

1.2 Additional Items Required

The following cable is required for OBD-II installation. It must be ordered separately and is not included in the dashcam kit. Order it using the [Lytx Surfsight AI-14 Standard Price List order form](#).



Power Only Y-Cable, AI-14

This cable connects the dashcam to the vehicle's OBD-II port whilst leaving the port accessible for other devices.

Required Tools

<input type="checkbox"/> Wire cutter	<input type="checkbox"/> Tape measure (5 m / 16 ft)
<input type="checkbox"/> Voltmeter or multimeter	<input type="checkbox"/> Marking pen
<input type="checkbox"/> Vehicle panel removal tool	<input type="checkbox"/> T6 security Torx bit
<input type="checkbox"/> Screwdriver set (Phillips and flat blade)	<input type="checkbox"/> Zip/cable ties
<input type="checkbox"/> Electrical tape	<input type="checkbox"/> Mobile device with internet access

NOTE: Refer to the vehicle manufacturer's manual for any special tools or parts required for maintenance, service, or diagnostics.

Optional Tools

<input type="checkbox"/> Cordless driver	<input type="checkbox"/> Paper/shop towels
<input type="checkbox"/> Grommets and looms	<input type="checkbox"/> Utility knife
<input type="checkbox"/> Heat torch	<input type="checkbox"/> Vehicle-specific panel clips
<input type="checkbox"/> Heat shrink	<input type="checkbox"/> Self-amalgamating tape

1.3 Identify Your Mounting Bracket

The AI-14 dashcam kit includes either a V1 or V2 mounting bracket. Identify which bracket you have before proceeding, as the installation steps differ.



AI-14 Mounting Bracket V1

The dashcam slides into this bracket from the right side and locks into place with two locating tabs.

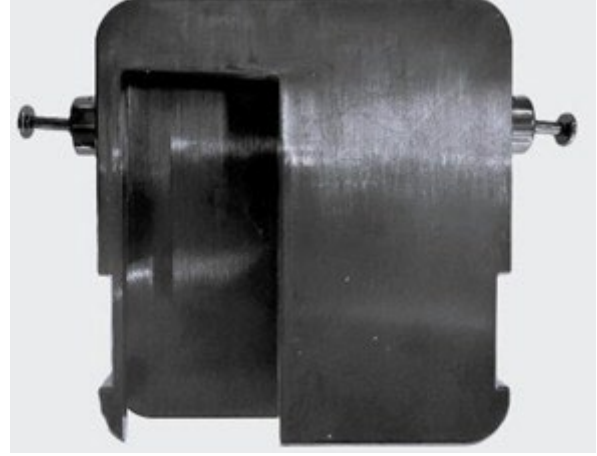

AI-14 Mounting Bracket V2

The dashcam slides into this bracket vertically and is secured with two Torx T6 screws.

For additional product information and cloud platform guidance, visit the Surfsight Help Center:
kb.surfsight.net/hc/en-us

2. Pre-Installation Checklist

Complete all of the following checks before beginning the installation.

1. Turn on the vehicle and confirm that no Malfunction Indicator Lights (MILs), error codes, or warnings are present on any displays. Cycle through messages if needed.
2. Verify that all necessary components are present. Record both the AI-14 IMEI number and the device serial number.
 - To locate the International Mobile Equipment Identity (IMEI) number, check the printed sticker on the dashcam and on the back of the packaging box. You will need this number for device setup and technical support.

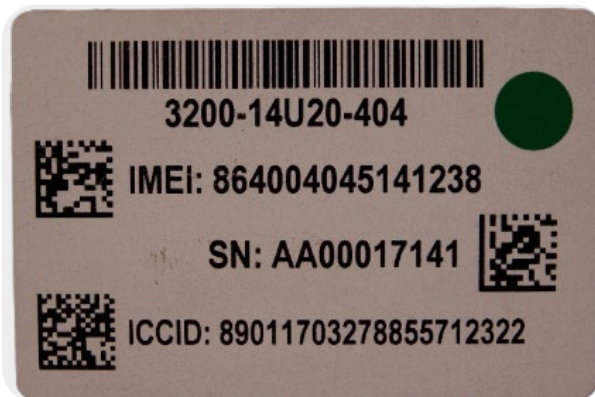

3. Inspect the windscreen for cracks or chips. Obtain client/end-user confirmation before proceeding if damage exists.
4. Check the vehicle's exterior for damage and report any findings before starting.
5. Inspect the vehicle's interior for damage or cleanliness issues. Report any findings before starting.
6. Photograph and document any dashcam warnings, windscreen damage, vehicle damage, or missing components. Report as per **Step 8**.
7. Confirm that no third-party devices are connected to the OBD-II port.
8. Report any faults or damage to the site contact and/or partner/manager before continuing.

3. OBD-II Port Setup

WARNING: Ensure that all wiring and installation steps do not interfere with any airbag systems or the vehicle's normal operation.

To use all features of the AI-14 dashcam, including Standby mode, connect it to a constant 12V or 24V power source with a minimum of 2A. For OBD-II installations, this is achieved by connecting the AI-14 OBD-II Power Only Cable to the vehicle's OBD-II port.

The OBD-II port is located in the driver's compartment, typically under the dashboard near the driver's knees, or behind a small access panel. The images below show left-hand drive (LHD); right-hand drive (RHD) is the reverse.

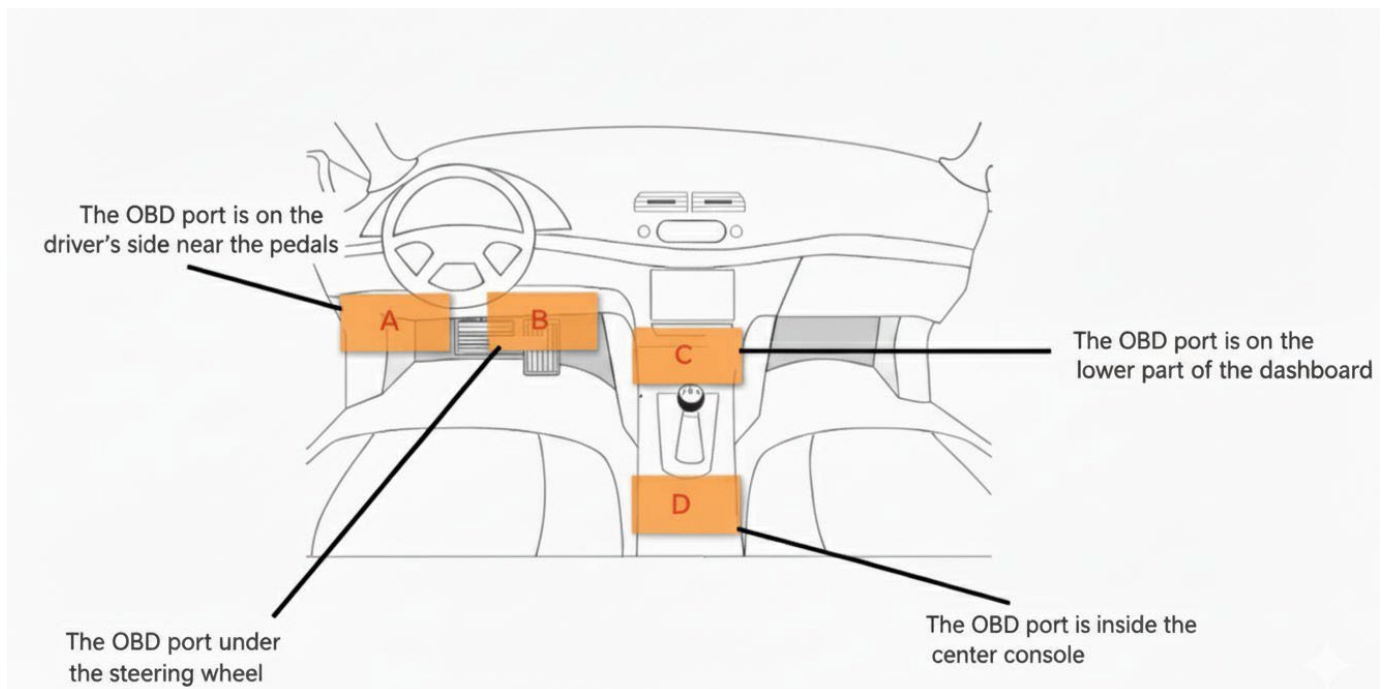

NOTE: Some vehicle manufacturers now require an open OBD-II port. The AI-14 OBD-II Power Only Cable uses a Y-cable design to keep the port accessible.

NOTE: Whilst in standby mode, you can retrieve recordings from the dashcam. Note that this will activate full power consumption, which may affect vehicle battery storage.

3.1 Connect to the Vehicle's OBD-II Port

1. Locate the on-board diagnostic port, usually found in the driver area, at or below knee level.



LHD



RHD

2. Select the correct adaptor for your vehicle type and slide it over the female OBD-II port on the Power Only Y-Cable. Insert the metal 'C' clips by hand. To remove the clips, use the tool shown below.

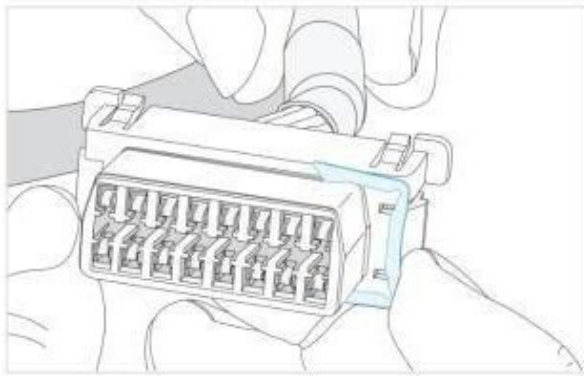

Insert

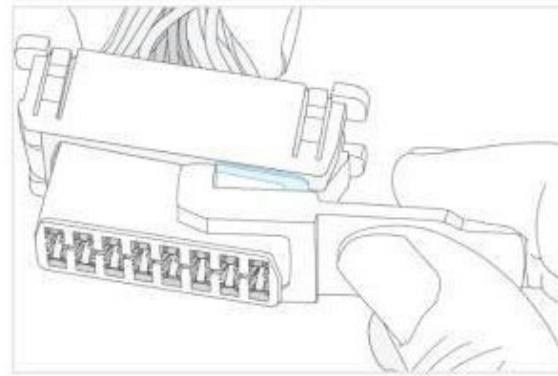

Remove

3. Connect the OEM OBD-II female port to the 16-way male port on the Power Only Y-Cable and secure with cable ties.

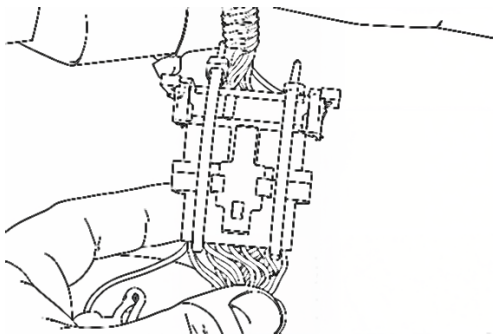

4. Route the AI-14 OBD-II Power Only Cable (Molex plug) from the vehicle's OBD-II port to the dashcam's mounting area. Ensure the connected Molex plug remains accessible for future maintenance.

5. Temporarily connect the female Molex plug on the Power Only Cable to the male Molex plug on the dashcam.
- Do not route the Molex plug behind panels at this stage. The temporary connection is for validating the mounting position.

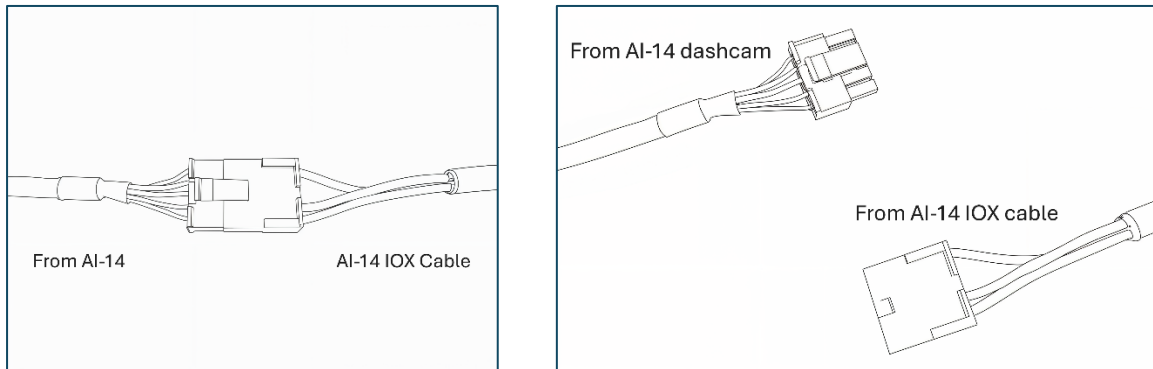

6. Route the power cable to avoid all SRS (Supplemental Restraint System) components, including airbags. Secure with cable ties every 30 cm (12 in) along its length.

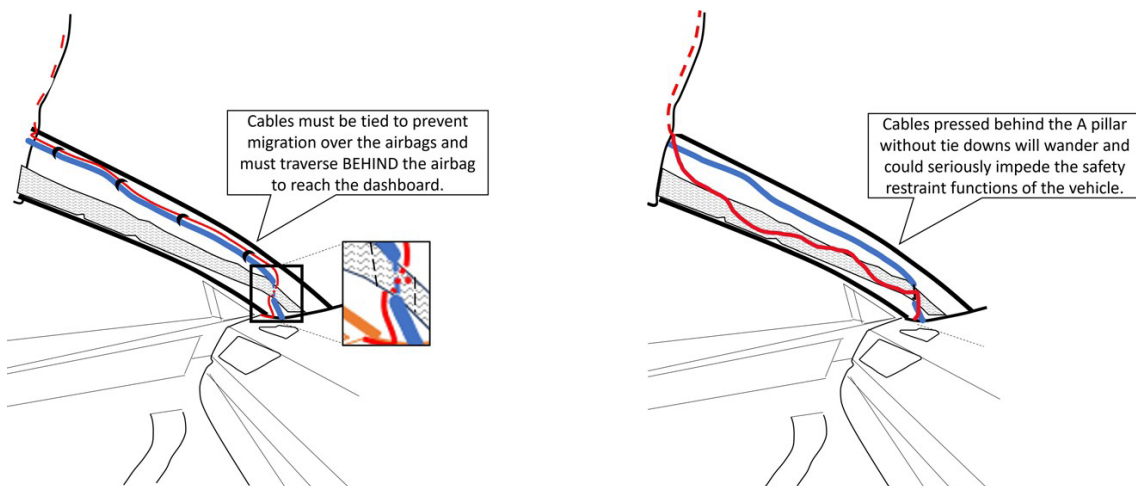

WARNING: Make certain that neither the wiring cables nor your installation activities interfere with any SRS-related mechanisms or otherwise risks affecting SRS airbag deployment. Consult the vehicle manufacturer for the location of any airbag sensors, systems, and restrictions that may apply.

7. Route the cable away from sharp edges and moving parts. Do not route cables where they could be pinched, such as in door jambs or check straps.
8. Confirm the connected Molex plug is accessible for future maintenance.
9. Secure cables with cable ties at regular intervals (every 30 cm / 12 in) so that cables are held firmly in place without sagging.
- Do not loop excess cable. Form a flat, elongated bundle shape and secure with cable ties.

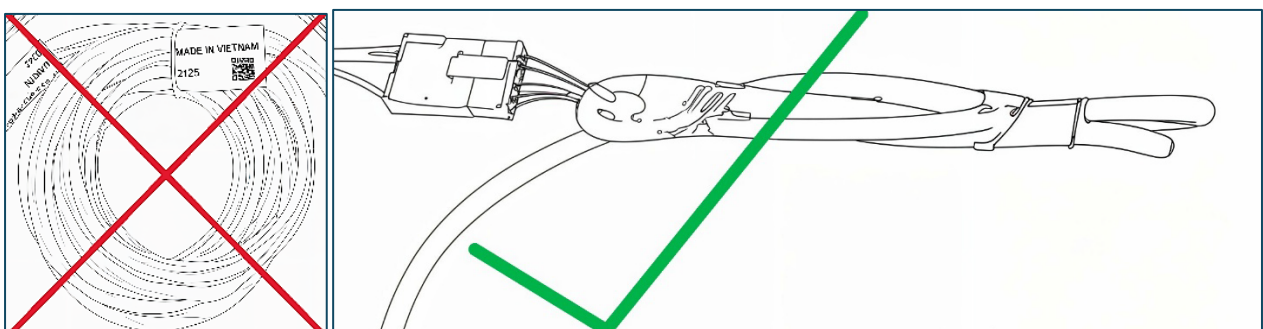

10. Start the vehicle to test the dashcam.
11. Validate the dashcam's mounting location using the **Live View** function (see [Section 5](#)).
12. Secure all installed components and cable runs. Replace any vehicle panels that were removed.
13. Complete the installation and test all components.

3.2 Configure Virtual Ignition

Configure the virtual ignition in the dashcam's **Settings** menu. Virtual ignition must be **ON** for OBD-II connections so that the dashcam activates when it detects vehicle movement.



After completing the installation, confirm that the vehicle is operating normally and that no unintended changes have occurred.

3.3 Adjust Dashcam Settings

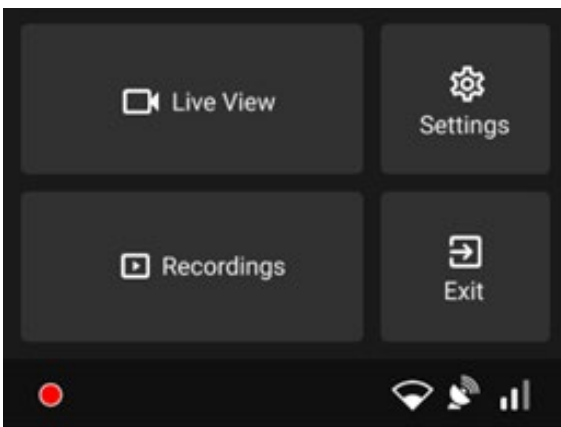

Before leaving site, power on the dashcam and adjust the following settings in the **Settings** menu.

Enter the default **PIN 3333** to unlock the dashcam for the first time, or enter your own administration PIN subsequently.

- **Driver Position:** Left or Right

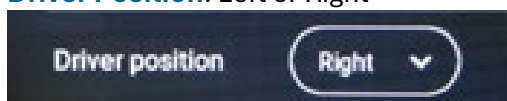

- **Speed Units:** km/h or mph



4. Position the Dashcam

WARNING: Some countries/regions/jurisdictions have adopted, or may in the future adopt, laws that prohibit objects from being mounted on a vehicle's windshield or other locations in a vehicle. Always refer to any applicable laws that concern mounting devices on vehicle windshields before choosing a mounting location. You are responsible for complying with such laws, as Lytx, Inc. does not accept responsibility for your failure to do so.

4.1 Regulatory Guidance



For the United Kingdom, refer to the following government guidance:

- MOT inspection manual for private passenger and light commercial vehicles — Section 3: Visibility
- HGV inspection manual
- PSV inspection manual
- Stickers or other items in front and rear windscreens — view to the front and windscreen obscuration

For other countries, validate applicable regulatory guidance as per the safety warnings in this guide. Common regulations include:

- USA: FCC Part 15 rules
- Global: ISO 16505 Regulation for camera monitoring systems
- Europe/Global: UNECE Regulations R046r7e / R125r3e / R167e / GRSG-122-24e / ECE/Trans/WP.29
- Consult vehicle roadworthiness testing center manuals for your country/region/jurisdiction.

4.2 Set the Viewing Angles

NOTE: Both the exterior and interior views adjust together. Separate lens adjustments are not supported.

Mount the dashcam on the windscreen in a position that allows both lenses to rotate freely together. This ensures optimal footage from both directions without limiting either lens's field of view.

1. Make sure the vehicle is parked with the parking brake engaged, the ignition on, and all doors closed.
2. Loosen the screw where the mounting bracket meets the dashcam body.



3. Press the touchscreen to display the **PIN** screen. Enter the default PIN **3333**, or your own PIN.

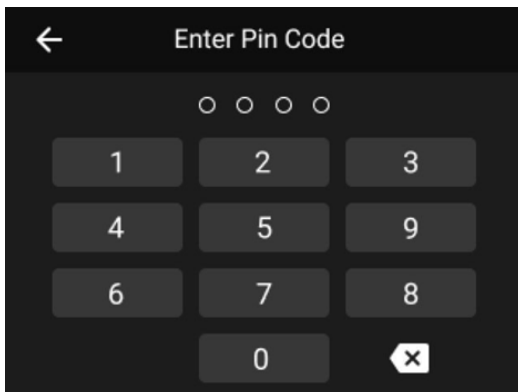

→ Refer to [Set and Manage your Dashcam PIN](#) in the Surfsight Help Center if you need help with your PIN.

4. Select **Live View**. Use **Live View** to check the position of both lenses. Toggle between the road-facing and in-cabin views using the arrow keys.

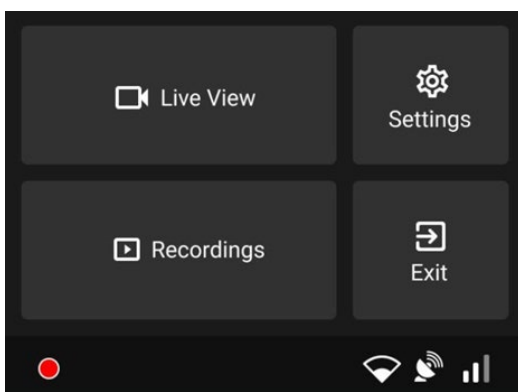

5. Position the dashcam and bracket on the windscreen to check the view, without peeling off the mounting tape.
 - The installer's upper body, or the full view of the driver's seat, should be in view of the in-cabin lens during positioning to ensure the correct placement for operation.
6. Tighten the screw where the mounting bracket meets the dashcam body once the view is correct. This locks both lenses into position.
7. Mark the edges of the bracket on the windscreen with a non-permanent marker.

4.3 Choose a Mounting Location

For vehicles with a rear-view mirror:



For vehicles without a rear-view mirror:



Select a windscreen location using the zone guide below:

1. **Green zone:** Recommended mounting area.
2. **Yellow zone:** Acceptable only if the driver's full upper body is visible and the dashcam does not obstruct the driver's view of the road.
3. **Red zone:** Do not mount here.

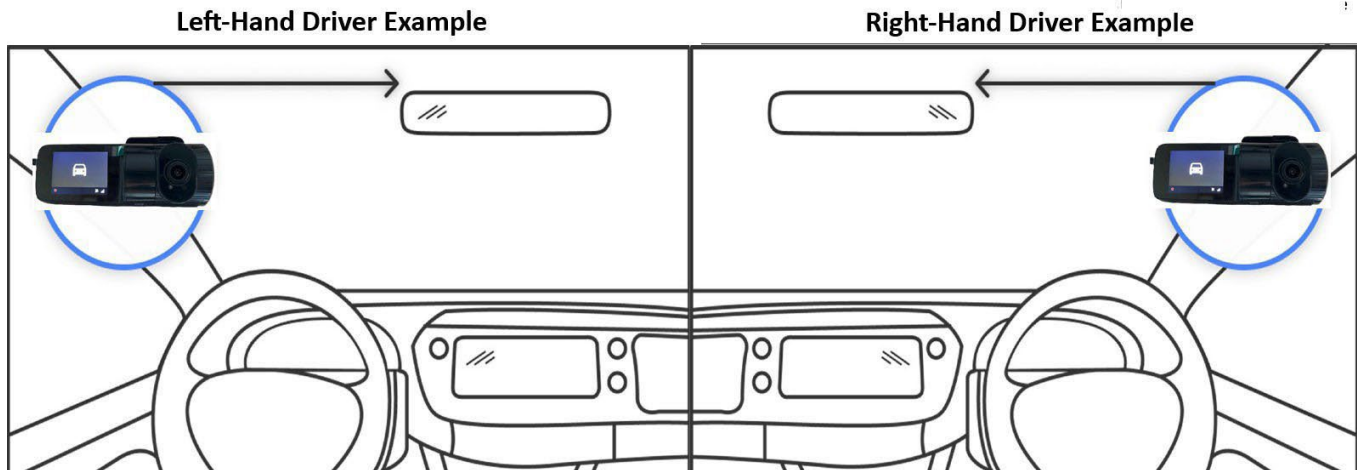

When choosing a mounting location, ensure that:

- The dashcam does not obstruct the driver's view of the road.
- The in-cabin lens has a clear, unobstructed view of the driver's head and torso (not blocked by sun visors or mirrors during normal operation).
- The road-facing lens has a clear view of the road with minimal sky visible.
- The windscreen has minimal curvature at the chosen location.
- Local view-of-the-road regulations are observed.

The driver's upper body must be in view of the in-cabin lens during operation.



If the dashcam cannot capture the driver's upper body from its primary position, mount it below the rear-view mirror, as high as possible without obstructing the driver's view.

Confirm that:

- There is a clear view of the road.
- The dashcam does not obstruct the driver's field of vision.
- The dashcam is within the vehicle's wiper path so the road-facing lens is not obstructed by rain or snow.
- Nothing in the cab blocks the in-cabin lens (sun visors, blinds, or mirrors).

5. Mount the Dashcam

5.1 Position and Install the Mounting Bracket

Step 1: Select and Prepare the Mounting Location

1. Choose a windscreen location that does not obstruct the driver's view, vehicle controls, visor, or the SRS.



2. Using the **Live View** function, temporarily position the dashcam to confirm clear views, then mark the spot.
3. Clean the marked area thoroughly with the alcohol wipe and allow it to dry completely.

WARNING: Make certain that neither the wiring cables nor your installation activities interfere with any SRS-related mechanisms or otherwise risks affecting SRS airbag deployment. Consult the vehicle manufacturer for the location of any airbag sensors, systems, and restrictions that may apply.

Step 2: Attach the Bracket to the Marked Area on the Windscreen

1. Peel off the adhesive cover.
2. Align the mounting bracket with the marked spot and apply even pressure, rolling it onto the windscreen from top to bottom.
3. Smooth out any large air bubbles by applying more pressure. If necessary, use a small pin to release trapped air.
4. Wait 10 minutes before attaching the dashcam so the adhesive can set.

5.2 Secure the Dashcam to the V1 or V2 Mounting Bracket

Follow the instructions for your bracket type.



AI-14 Mounting Bracket V1

The dashcam slides into this bracket from the right side and locks into place with two locating tabs.

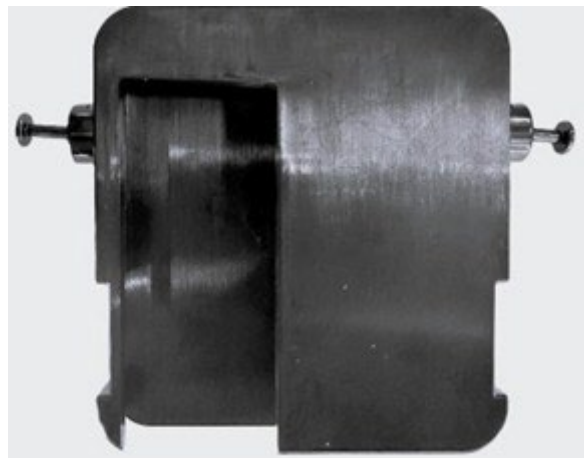

AI-14 Mounting Bracket V2

The dashcam slides into this bracket vertically and is secured with two Torx T6 screws.

(V1) Step 3: Secure the Dashcam to the V1 Bracket and Confirm Views

The dashcam slides into the V1 bracket from the right side and locks into place with two locating tabs. Be sure to leave at least **12.5 cm** (4.9 in) to the right of the dashcam to allow room for insertion.

To attach the dashcam to the V1 mounting bracket:

1. Slide the dashcam body into the mounting bracket from the right side until it clicks into place.

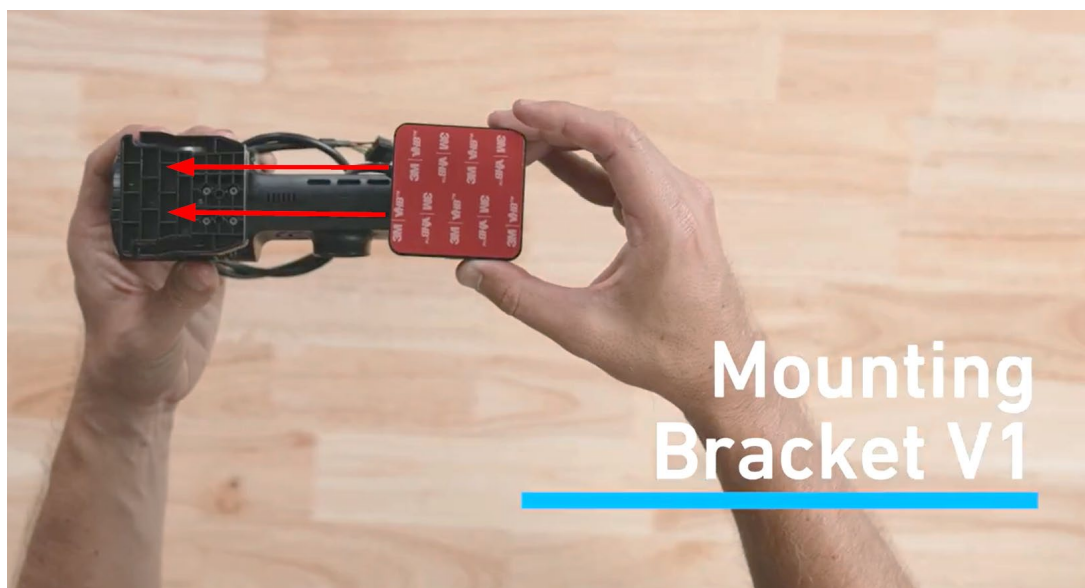

2. Power on the dashcam, go to **Live View**, and verify clear in-cabin and road-facing lens views.
→ See [Section 4](#) for lens view guidance.
3. Tighten the Torx T6 screw where the mounting bracket meets the dashcam body to lock the dashcam angle and view in place.



NOTE: Do not overtighten. The T6 has a torque specification of 0.8 Nm.

(V2) Step 3: Secure the Dashcam to the V2 Bracket and Confirm Views

The dashcam slides into the V2 bracket vertically and is secured with two locating tabs and two Torx T6 screws.

To attach the dashcam to the V2 mounting bracket:

1. Slide the dashcam body upwards into the bracket until the locating tabs click.



2. Secure the two Torx T6 screws on either side of the mounting bracket.



3. Power on the dashcam, go to **Live View**, and verify clear in-cabin and road-facing lens views.
→ See [Section 4](#) for lens view guidance.
4. Tighten the Torx T6 screw where the mounting bracket meets the dashcam body to lock the dashcam angle and view in place.



NOTE: Do not overtighten. The T6 has a torque specification of 0.8 Nm.

6. ADAS Calibration

The AI-14 dashcam uses road-facing Advanced Driver Assistance Systems (ADAS) to detect events like critical following distance. To enable ADAS calibration, you must record three measurements in either centimeters or inches:

1. Dashcam road-facing lens height from the ground.
2. Width of the front axle from the outer edges of each tire.
3. Dashcam offset from the center of the windshield, measured from inside the cabin to the road-facing lens.
 - When the dashcam is to the right of center, enter a negative value.
 - When the dashcam is to the left of center, enter a positive value.

IMPORTANT: The dashcam must be installed at least 1 meter (39.3 in) above the ground before beginning ADAS calibration.

You can enter ADAS measurements directly on the AI-14 touchscreen or provide them to a reselling partner. The steps in [Section 6.2](#) below cover the touchscreen method.

6.1 Measurement Guidance

Dashcam Height from the Ground



Front Axle Width from the Outer Edges of Each Tire



Dashcam Offset from Center of Windscreen

When the dashcam is to the right of center, enter a negative value. When the dashcam is to the left of center, enter a positive value.

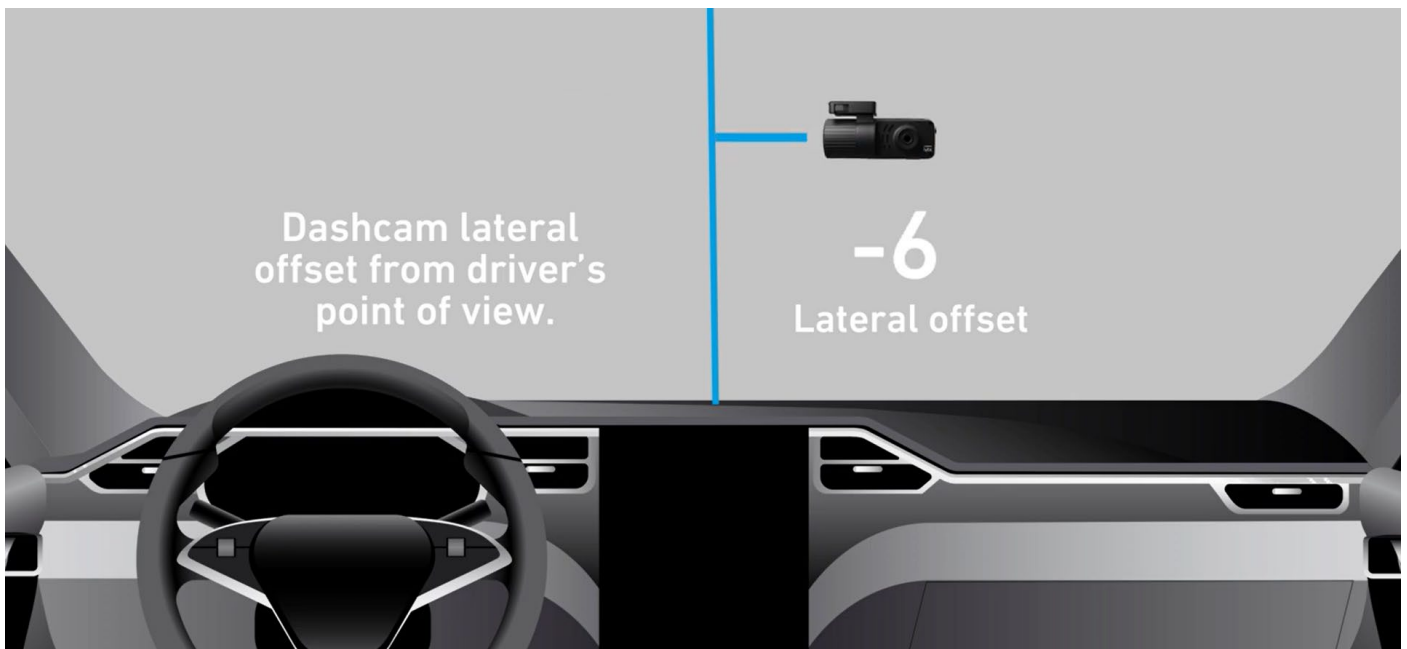
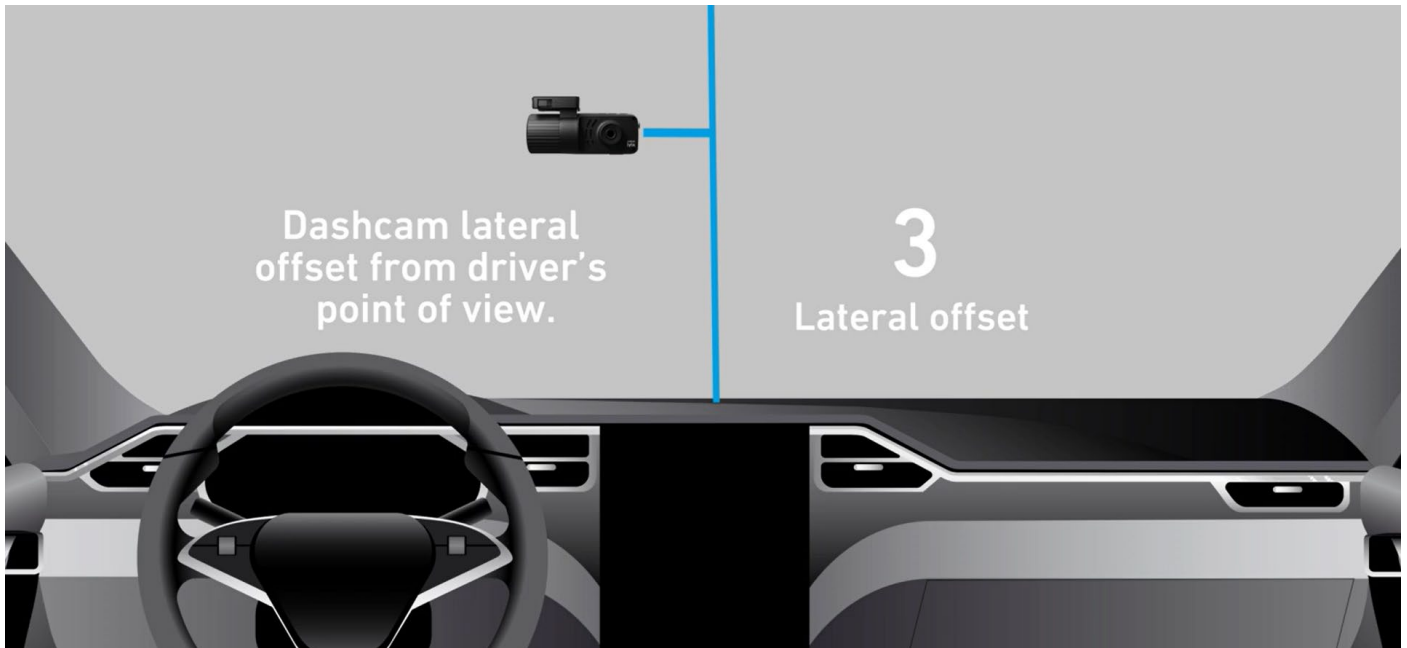

Offset views (from inside the cabin)

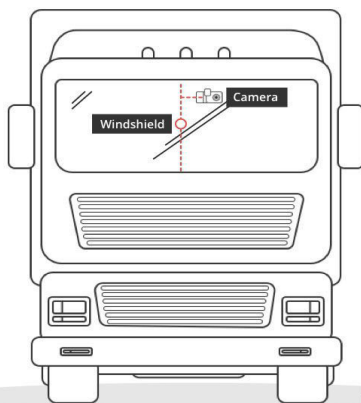

Offset camera left

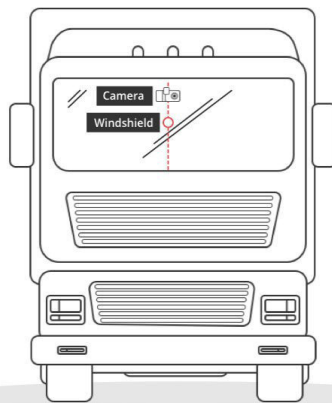

Offset camera center

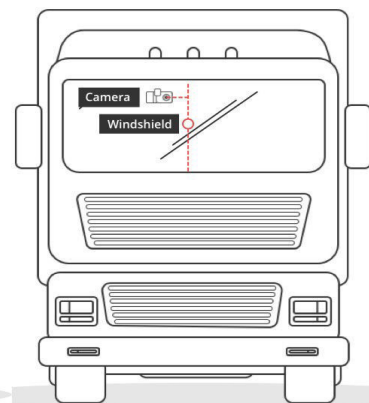

Offset camera right

6.2 Enter Measurements in Dashcam ADAS Settings

To access ADAS settings:

1. Unlock the dashcam by entering the PIN. The default PIN is 3333.
2. Navigate to **Settings** from the main menu.
3. Scroll through settings to confirm that Speed Units and Driver Position are set correctly.

To enter measurements, navigate to **Settings** in your dashcam:

1. Select the measurement units from the drop-down menu: inches or centimeters.
2. Select **Start Configuration** in the **ADAS – Not Calibrated** section.

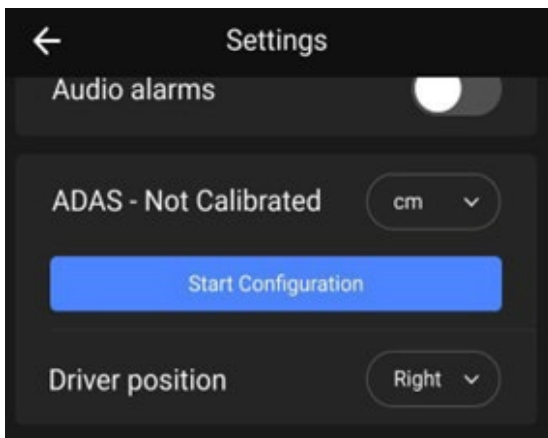

3. Begin your measurement configuration. Select **Next**.

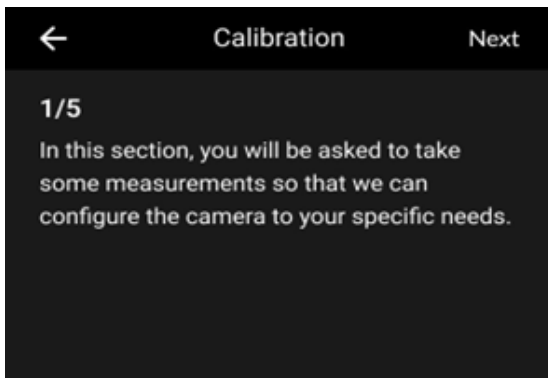

4. Enter the height measurement you took from the ground to the dashcam. Select **Next**.

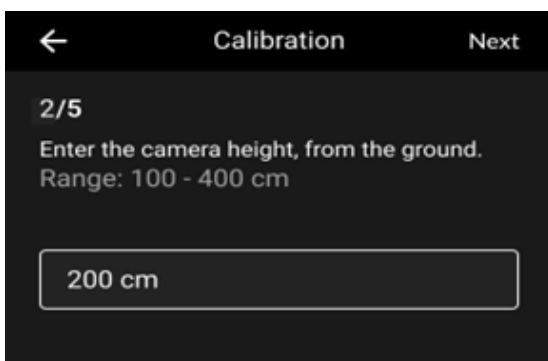

5. Enter the axle width. Select **Next**.

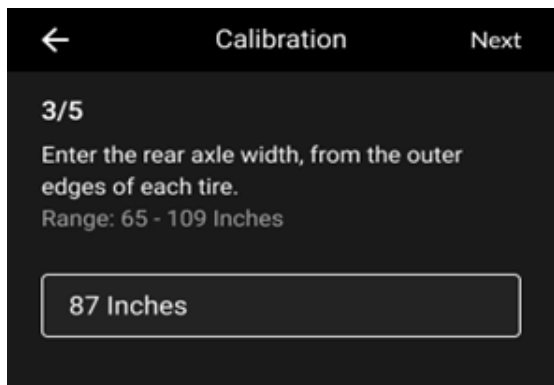

6. Use the arrows to adjust the dashcam's offset from the center of the windshield. The left arrow decreases the value (down to -200 cm); the right arrow increases it (up to +200 cm). Select **Next**.

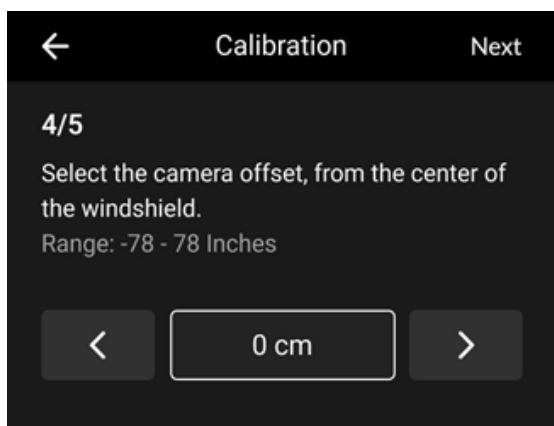

7. Review all entered measurements on the final summary screen. Select **Save** to finish.

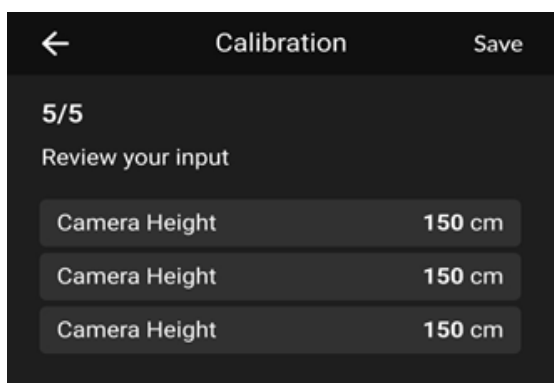

IMPORTANT: If the dashcam is re-mounted (e.g. after a windshield replacement), you must recalibrate and validate the measurement units.

7. Post-Installation Checklist

Before your installation is complete, record and/or take pictures of:

- The dashcam's mounted position on the windscreen (with sun visor open and closed).
- The **Live View** on the touchscreen for both road-facing and in-cabin lenses.
- The OBD-II connection point.
- The overall installation and cable routing.
- The IMEI, vehicle registration, VIN, and ADAS measurements.
- Inspect the inside and outside of the vehicle for any damage or cleanliness issues and report findings.

7.1 Final Checks and Functionality

1. Secure all cables and correctly reinstall any panels removed during installation.
2. With the vehicle running, verify the dashcam's **Live View** to confirm it is operational.
3. Test lights, power windows, radio, and climate control (A/C and heat).
4. Confirm cellular connection and GPS by checking **More Info** in the **Settings** menu.
5. Check other critical vehicle functions as applicable.
6. Confirm the OBD-II port is clear and no unrelated devices are connected.
7. Start the vehicle to confirm no warning lights are present. If any appear, resolve the issue and inform the client and supplier.
8. Return the vehicle keys.

8. OBD-II Mounting Adapters

The table below lists the available OBD-II port adapters by type and compatible vehicle makes. Select the correct adapter for your vehicle before beginning installation (see [Section 3.1, Step 2](#)).

1-2U

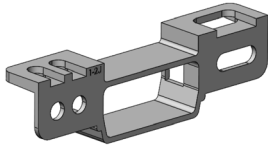

NORTH AMERICAN FLANGE MOUNT

- Ford
- GM
- Chrysler

3

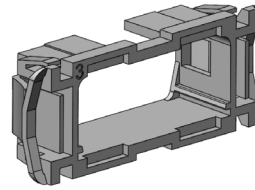

NORTH AMERICAN SNAP-IN MOUNT

- Chrysler

4

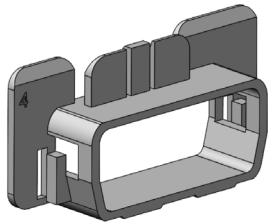

NORTH AMERICAN SLIDE & LOCK MOUNT

- Ford
- GM

5

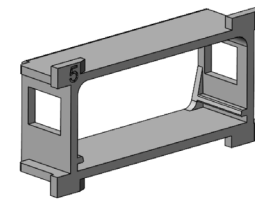

EUROPEAN LOCK MOUNT

- Mercedes
- BMW
- Iveco

6

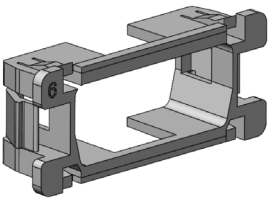

ASIAN SNAP-IN

- Toyota
- Hyundai
- Kia
- Ford
- Honda
- Iveco

7

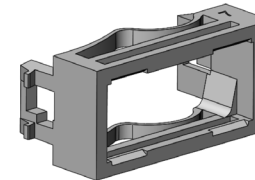

EUROPEAN LATCH & SNAP

- Fiat
- Citroën
- Peugeot

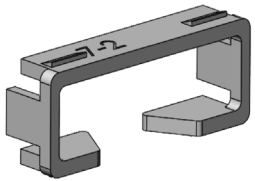

8

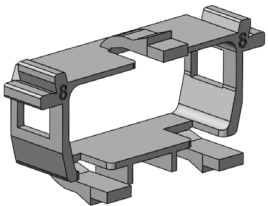

VW SNAP-IN

- Volkswagen
- Audi
- Bentley
- Porsche
- Skoda
- SEAT

9

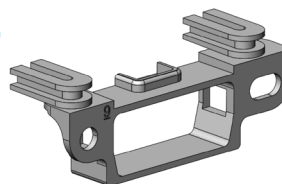

BMW SLIDE & LOCK

- BMW

10

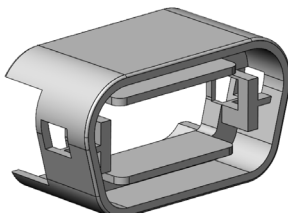

FORD ROUND SNAP-IN

- Ford

11

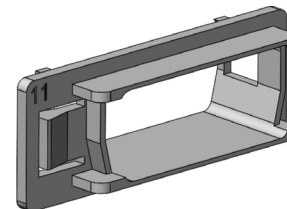

MAN/DAF SLIDE & LOCK

- MAN / DAF

12

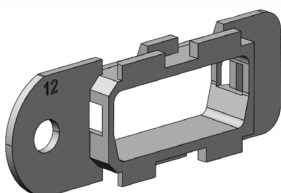

VOLVO SLIDE MOUNT

- Volvo

13

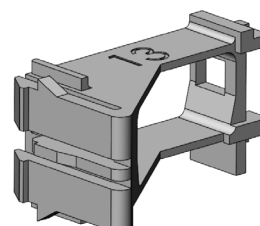

HEAVY-DUTY VOLVO SLIDE MOUNT

- Volvo (HD)
- Scania
- MAN

9. Frequently Asked Questions

Question	Answer
How do I change the date and time on the dashcam?	The date and time are determined by the mobile network and cannot be changed manually. If the vehicle travels between time zones, the dashcam automatically adjusts to the local time. You can change the date format in the Settings menu.
How do I know the dashcam records for 10 minutes after the ignition is turned off?	The dashcam records for a minimum of 10 minutes after the ignition is turned off, provided it is connected to constant power.
How do I know the dashcam enters standby mode?	If the dashcam has a hardwired ignition connection, the green LED turns off after the selected standby timeout. For OBD-II installations, activate the virtual ignition in the dashcam's Settings menu.
What happens if I power off using the master switch?	The dashcam has a capacitor to ensure a soft shutdown when constant power is disconnected.
What do I do if I forget my PIN?	Contact your reseller support agent.
What measurement units does the dashcam support?	The dashcam supports kilometers per hour and miles per hour, configurable in Settings .
What units should I use for ADAS measurements?	If the dashcam is set to km/h, use centimeters. If set to mph, use inches.
The dashcam defaults to inches. How can we calibrate using centimeters?	You can change the measurement units for each dashcam or convert values when entering measurements. In the Partner Portal, you can switch between inches and centimeters at the start of the calibration process.
At what speed does road-facing ADAS activate?	The dashcam begins monitoring events once the vehicle exceeds 5 km/h.
Can rotating the dashcam lens trigger an event?	Yes, if the lens rotates and the g-force is significant, an event may be triggered. Fully tighten the T6 Torx screws during installation to prevent lens rotation.
How do I measure the dashcam height from the ground?	Measure from the ground to the floor of the vehicle, then from the floor to the dashcam, and add the two values. Alternatively, measure from the ground to a point level with the dashcam. Greater precision yields better ADAS performance.
Which point on the dashcam is used for offset measurement?	Measure from the center of the windshield to the middle of the road-facing lens.
Does seatbelt position affect Distracted Driving events?	Yes. For optimal detection, mount the dashcam where it has a clear, unobstructed view of the driver's face, upper body, and hands.
Why is the CALIBRATE ADAS button not visible in the Partner Portal?	The button appears only after calibration data has been prepared. Drive the vehicle above 75 km/h for approximately five minutes to obtain images for ADAS calibration.

Question	Answer
Why do drivers receive incorrect alerts?	This typically occurs when the driver's position setting is incorrect or the driver's upper body is not in view of the in-cabin lens.
Can the same encryption password be used across multiple SD cards?	Yes. The SD password is linked to the card itself, not the dashcam. Any password can be used for any card, and the same password can be used across multiple cards.
Why is the LED indicator off?	The LED can be disabled in the Partner Portal for a specific unit or client. Contact customer support for assistance.
The dashcam is not turning on. How do I verify power?	Check the Molex plug on the vehicle cable side. Verify pin assignments (Pin 1: Ground, Pin 2: Constant power, Pin 5: Ignition power). Inspect fuses and examine both vehicle and dashcam cables for damage.
Can I swap SIM cards?	Yes. After inserting the new SIM, perform a factory reset (this removes the one-time AT&T provisioning flag). Add the correct APN for the new SIM if it is not included in the device firmware. A factory reset is required whenever switching between AT&T and non-AT&T SIMs.
What if the dashcam does not power on?	Validate 12V / 24V at the Molex plug on both the red (constant) and brown (ignition) wires. If voltage is below 10V / 18V, find a different constant feed. With the engine running, the brown ignition wire should show approximately 14.8V / 28.4V. Try waking the unit via the event button or motion. Verify the virtual ignition setting. Contact technical support if the issue persists.

10. Service and Audit Calls

The following flowchart illustrates the service and audit call process.

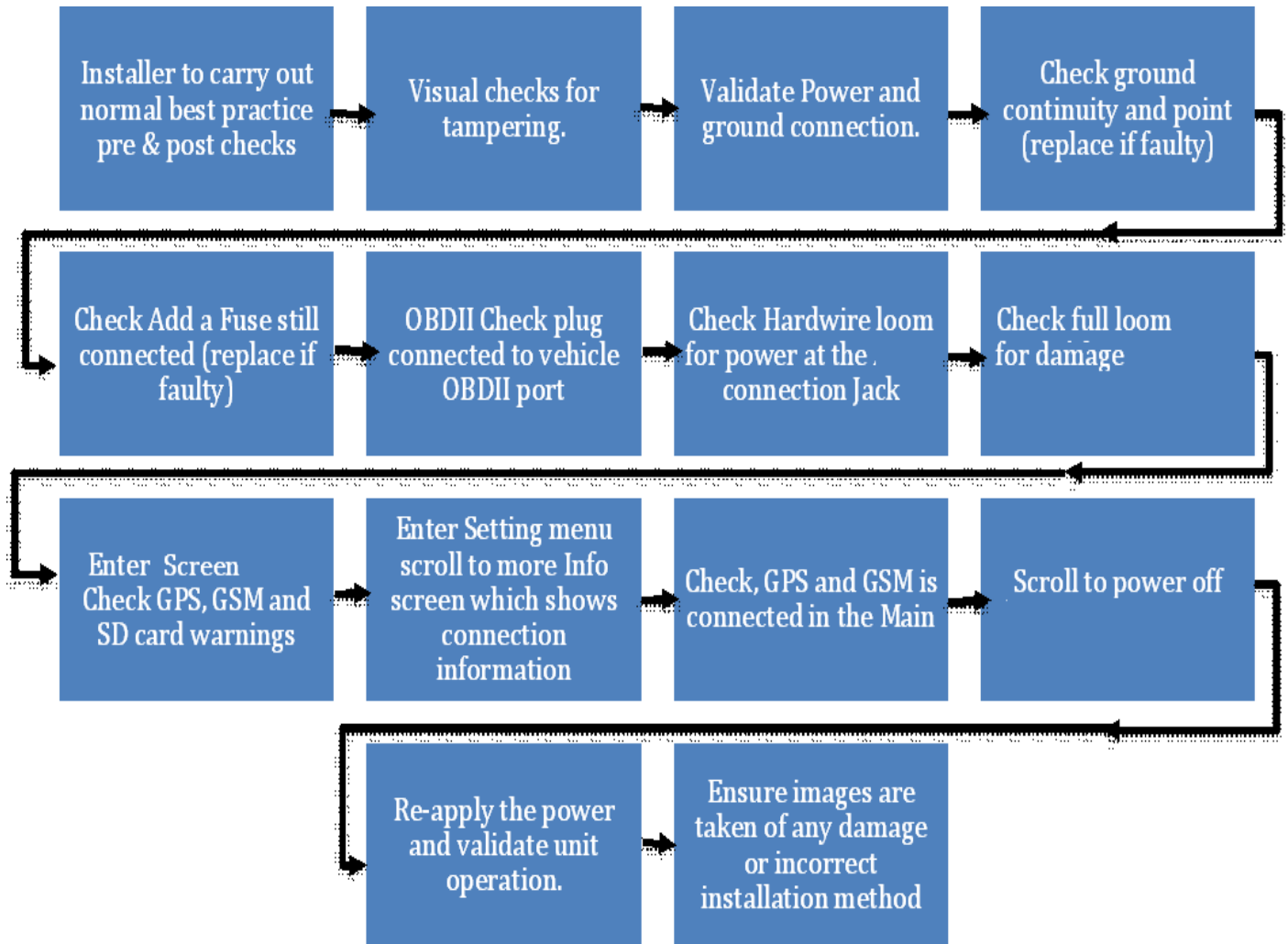

11. De-Installation

Before uninstalling the dashcam:

1. Confirm the unit is connected to GPS and GSM to verify operational status.
2. Enter the PIN, navigate to **More Information**, and take a diagnostic image.
3. Return to **Settings**, select **Power off**, and disconnect the power cable.
→ Keep the unit powered off to prevent battery discharge.
4. Remove or safely secure all cables.
5. Detach the mounting bracket from the vehicle.
6. Place the dashcam and all accessories in a box, labelled with the vehicle information.
7. Perform post-de-installation vehicle checks.
8. Return the equipment and vehicle keys to the client or site contact.

12. Safety Warnings Reference

The following safety warnings apply to all AI-14 dashcam installations. These are provided here as a consolidated reference.

Installation Warnings

- WARNING:** Some countries or regions have adopted, or may adopt, laws that prohibit objects from being mounted on a vehicle's windshield or other locations. Always refer to applicable laws before choosing a mounting location. You are responsible for compliance.
- WARNING:** The Surfsight camera(s) interfaces with the vehicle's electrical systems. However, it should not interfere with any of the vehicle's electrical or operating systems, including SRS (Supplemental Restraint System) deployment. Lytx, Inc. disclaims all responsibility for any damages arising from improper installation and maintenance of the Surfsight camera(s).
- WARNING:** Park the vehicle on a level surface before beginning any maintenance or installation. Block the wheels to prevent the vehicle from moving. Never work under a vehicle supported only by jacks, as jacks can slip and fall over.
- WARNING:** All wires that carry electrical current to the Lytx device(s) must be fused. Failure to fuse the constant power and ignition wire can lead to serious personal injury and/or property damage. If any wire or cable containing a fuse or fuse box needs to be cut or shortened or extended, always replace such fuses/fuse boxes or install new ones.
- WARNING:** Only approved wire connection methods are recommended. Refer to the vehicle manufacturer's service manual to determine if sealing crimp connections, Add-A-Circuit, sealing butt connections, or OEM connections to open connection ports are approved. Never use plier-tap products such as insulation displacement connectors (e.g., ScotchLok connectors) when installing the Surfsight device(s), unless mandated by the vehicle manufacturer (e.g., BMW).
- WARNING:** Wire Protection: Take all necessary measures to protect wire runs through metal surfaces with a grommet or other device, and all wire runs outside the vehicle cab with a loom. Always protect against wire fatigue and harness abrasion by properly attaching wires at closely spaced intervals, while avoiding contact with sharp edges or anything else that might result in exposed wires. Secure all wires with tie wraps at least every one foot (30 cm) or less. Do not over-tighten tie wraps.
- WARNING:** Use the correct Personal Protective Equipment (PPE) to comply with health and safety regulations for the installation site and type of installation being completed. Wear eye protection to prevent serious injury when performing vehicle maintenance or service.
- WARNING:** Locate your fuse box. Always refer to the vehicle manufacturer's service manual or upfitter (body builder) sites for proper installation and wiring of any aftermarket devices, including the Surfsight AI-14. Check the owner's manual to find the fuse box, which may vary by vehicle model.
- WARNING:** Never wire the Surfsight device(s) in a manner that shares a connection with another aftermarket product in the vehicle. Independent connections should always be used.
- WARNING:** Ensure that all wiring and installation steps do not interfere with any airbag systems or the vehicle's normal operation.
- WARNING:** This installation must be performed by a qualified professional. Working with your vehicle's power system can be dangerous. Consult a professional for guidance.
- WARNING:** Substituting or supplementing components may impair suitability and performance. If you are missing any components, contact Lytx Technical Support Center at 925.732.4246 or email support@lytx.com.
- DANGER:** EXPLOSION HAZARD: Do not disconnect equipment unless power has been removed and the area is known to be non-hazardous. Comply with all EV/non-ICE vehicle health and safety requirements. Electrical work on electrically propelled vehicles should only be performed by a suitably trained and qualified automotive technician with an international Level 1 EV qualification applicable to your country or region.
- CAUTION:** Routing the cable underneath the window and door trim may be necessary. This trim is typically held by snap-fit clips. In vehicles with side and curtain airbags, these clips are often designed for single use and will need to be replaced once removed. Refer to the vehicle service manual for detailed removal and replacement procedures.
- IMPORTANT:** Only a properly qualified technician should install and maintain the Surfsight powered by Lytx dashcam. Electrical work should be performed only by a suitably trained and qualified automotive technician with qualifications applicable to your country or region, and with expertise in installing and troubleshooting advanced onboard components, including multiplexed circuits.
- IMPORTANT:** Make sure that wiring cables and installation activities do not interfere with any airbag-related mechanisms or normal vehicle operations. Ensure cables are clear of sharp edges, moving parts, and cannot get pinched in the door jamb. Tuck cables behind panels wherever possible and secure them with cable ties at least every foot (30 cm) or as necessary.
- IMPORTANT:** Install the dashcam at least 1.6 meters (63 inches) from the ground to ensure proper operation of the road-facing ADAS capabilities.
- IMPORTANT:** If the camera is remounted due to a windshield change or relocation, the dashcam must be recalibrated, and the measurement units validated.
- NOTE:** Some vehicle manufacturers now require an open OBD-II port. This can be achieved by using an OBD-II Y-interface cable, which is not included in your kit.
- NOTE:** Verify the OBD-II cable is securely connected to the vehicle OBD-II port.
- NOTE:** The dashcam can be positioned on the passenger side or centrally below the rear-view mirror, considering the vehicle's design and the driver's view. Ensure placement complies with local windshield obstruction laws and regulations.
- NOTE:** Consult the vehicle's maintenance, service, installation, and diagnostic guidelines provided by the manufacturer for any additional or special tools or parts needed.

Driver Safety Warnings

WARNING: In order to reduce the potential danger of injuries, the driver and front passenger must always be correctly seated with seat belts correctly fastened when operating the vehicle.

DISCLAIMER: The Lytx device is a driver aid only, not a substitute for a safe, conscientious driver. The Lytx device cannot compensate for a driver who is distracted, inattentive or impaired by fatigue, drugs or alcohol. Whether or not the Lytx device is in use, it is always the responsibility of the driver to take appropriate corrective action. Never wait for the device to provide a warning before taking measures to avoid an accident. Failure to do so can result in serious personal injury or death or severe property damage.

WARNING: The ability for the Lytx device to issue a warning, including a visual and/or audible alert may be limited. In certain conditions, including inclement weather, low visibility, certain road conditions (including poor lane markings, construction zones, dirt roads, heavy or complicated traffic, and curvy and winding roads), the Lytx device may have limited to no functionality. Further, certain factors within the vehicle, including the body positioning of the driver and/or passengers and other in-vehicle equipment, can impact the ability for the Lytx device to issue a warning. The Lytx device may not detect certain objects such as motorcyclists, bicyclists or pedestrians even in the most ideal conditions. Always keep the lens and view of the Lytx device unobstructed and properly calibrated so as not to inhibit function.

WARNING: The Surfsight dashcams comply with the user-accessible surface temperature limits defined by the International Standards for Safety IEC 62368. However, they may become warm during normal use, and prolonged contact with warm surfaces can cause discomfort or injury. To minimize any potential heat-related issues, please avoid touching the dashcam's lens surface.

WARNING: If the Lytx device is not functioning properly at any time, please contact your supervisor and have the device inspected immediately to correct the issue. Whether or not the Lytx device is functioning, it is the driver's responsibility to maintain vehicle control; failure to do so can result in serious personal injury or death or severe property damage.

WARNING: While cleaning the device or the vehicle cab, do not apply compressed air or cleaning solutions (such as Windex) to the Lytx device. Usage of these products may cause damage to the device.

WARNING: The optional livestream feature may have an approximate delay of 10 seconds. Livestream should never be used to assist the driver in operating the vehicle. The driver is responsible for the safe operation of the vehicle at all times and must always take measures to avoid a collision.

Local, State, and Federal Laws

USA Federal Communications Commission (FCC) Notice

This device complies with part 15 of the FCC Rules. Operation is subject to the following two conditions: (1) This device may not cause harmful interference, and (2) this device must accept any interference received, including interference that may cause undesired operation.

WARNING: Some countries/regions/jurisdictions have adopted, or may in the future adopt, laws that prohibit objects from being mounted on a vehicle's windshield or other locations in a vehicle. Always refer to any applicable laws that concern mounting devices on vehicle windshields before choosing a mounting location. You are responsible for complying with such laws, as Lytx, Inc. does not accept responsibility for your failure to do so.

WARNING: Changes or modifications not expressly approved by the party responsible for compliance could void the user's authority to operate the equipment.

The AI-14 dashcam (Model AI-14-010) wireless operation is safe and complies to RF Exposure requirements.

NOTE: This equipment has been tested and found to comply with the limits for a Class B digital device, pursuant to part 15 of the FCC Rules. These limits are designed to provide reasonable protection against harmful interference in a residential installation. This equipment generates, uses and can radiate radio frequency energy and, if not installed and used in accordance with the instructions, may cause harmful interference to radio communications. However, there is no guarantee that interference will not occur in a particular installation.

WARNING: Exposure to Radio Frequency Radiation. To comply with FCC RF exposure compliance requirements, for mobile configurations, a separation distance of at least 20 cm must be maintained between the antenna of this device and all persons.

Canada — Industry Canada Notice

This device contains license-exempt transmitter(s)/receiver(s) that comply with Innovation, Science and Economic Development Canada's license-exempt RSS(s). Operation is subject to the following two conditions: (1) This device may not cause interference. (2) This device must accept any interference, including interference that may cause undesired operation of the device.

AVERTISSEMENT: L'émetteur/récepteur exempt de licence contenu dans le présent appareil est conforme aux CNR d'Innovation, Sciences et Développement économique Canada applicables aux appareils radio exempts de licence. L'exploitation est autorisée aux deux conditions suivantes: (1) L'appareil ne doit pas produire de brouillage; (2) L'appareil doit accepter tout brouillage radioélectrique subi, même si le brouillage est susceptible d'en compromettre le fonctionnement.

WARNING: Exposure to Radio Frequency Radiation. To comply with RSS 102 RF exposure compliance requirements, for mobile configurations, a separation distance of at least 20 cm must be maintained between the antenna of this device and all persons.

AVERTISSEMENT: Pour se conformer aux exigences de conformité 102 RSS RF exposition, pour des configurations mobiles, une distance de séparation d'au moins 20 cm doit être maintenue entre l'antenne de cet appareil et toutes les personnes.

Europe — Radio Equipment Directive 2014/53/EU (RED)

This device complies with the requirements of the following standards: ETSI EN 301 908-1 V13.1.1(2019-11), ETSI EN 301 908-13 V13.2.0(2021-11) draft, ETSI EN 301 511 V12.5.1(2017-03).

This product complies with EN IEC 62311:2020 — Assessment of Electronic and Electrical Equipment related to Human exposure restrictions for Electromagnetic fields (0Hz–300GHz).

This device has both E-Mark and CE Mark, in compliance with UNECE regulation E/ECE/TRANS/505/Rev.2. This device may be installed throughout Europe and other regions that accept E-Mark or CE Mark as suitable proof of compliance. Regulations may vary per locality.

Supplier's Declaration of Conformance

Manufacturer: Lytx, Inc., 9785 Towne Centre Drive, San Diego, CA 92121 USA

Product: AI-14 dashcam. Models: AI-14-010, AI-14-011 (US/Can); AI-14-036 (EU/RSA); AI-14-046 (MX/LatAm/Aus/NZ).

EMC & Radio standards: FCC Title 47 CFR Part 15 Subpart B; FCC Title 47 CFR Part 15.247; FCC Part 15 Subpart E; Industry Canada ICES-003, Class B; Industry Canada RSS-Gen; Industry Canada RSS-210; Industry Canada RSS-247; 2014/53/EU (RED) Radio Equipment Directive; 2011/65/EU (RoHS) Restriction of the Use of Certain Hazardous Substances in E&E Equipment; EN 55032:2015: Electromagnetic compatibility of multimedia equipment.